

LT-CST-004

SPACE ABOVE CEILING MUST
BE VENTILATED

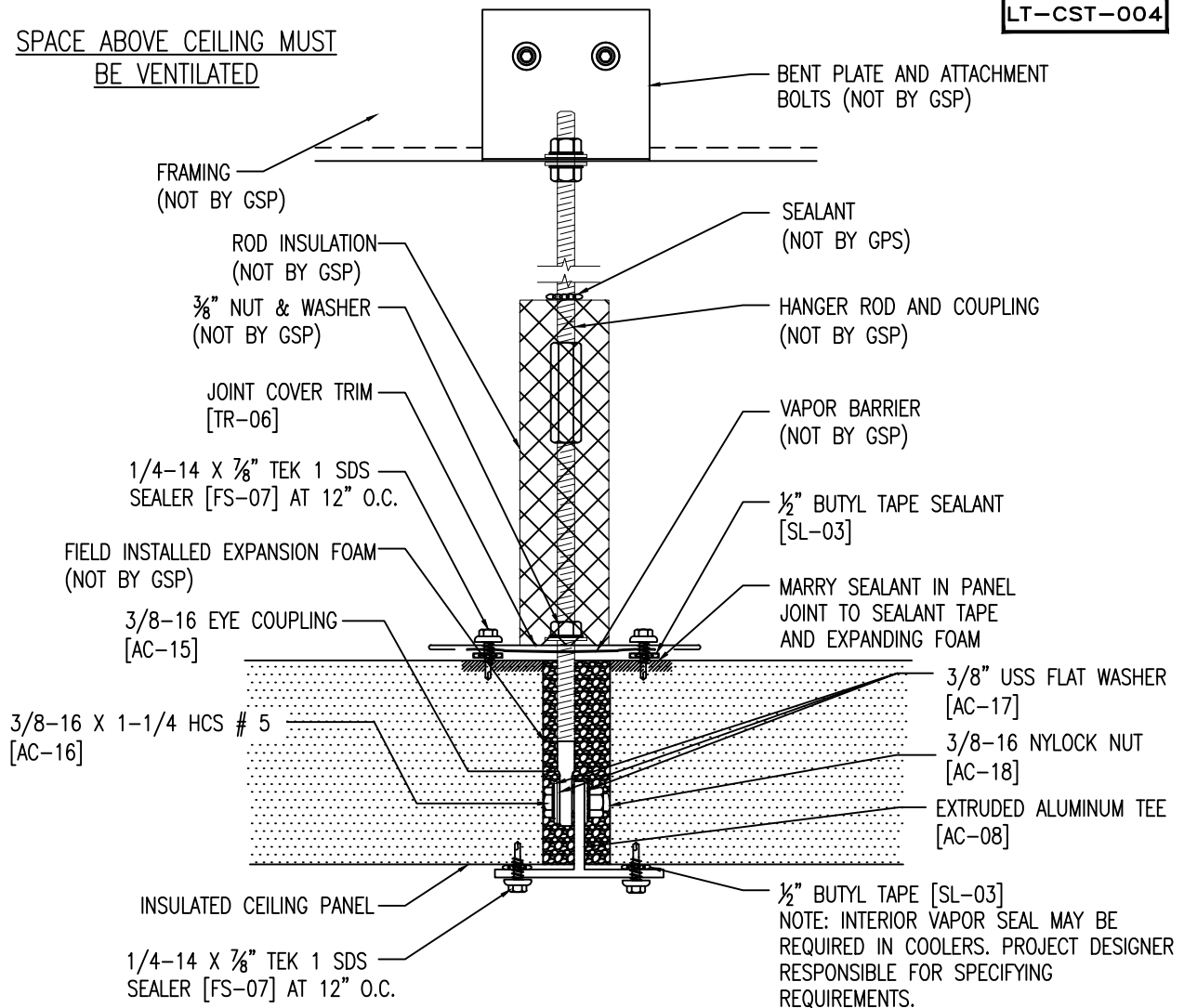

- NOTE:
1. ALL CEILING PANELS AND SUPPORT COMPONENTS MUST BE INSTALLED COMPLETE PRIOR TO ALLOWING ANY LOAD ON CEILING.
 2. THIS DETAIL IS ONLY VALID WITH 42" MAX. WIDTH INSULATED METAL CEILING PANELS.
 3. INTERIOR VAPOR SEAL IS MOST LIKELY REQUIRED. THE PROJECT DESIGNER IS RESPONSIBLE FOR SPECIFYING REQUIREMENTS.
 4. BRACING OF RODS MAY BE REQUIRED, DESIGN NOT BY GSP.
 5. FIELD CUT STARTING PANEL AND ENDING PANEL AS REQUIRED AT CEILING TRANSITION. USE OF RECIPROCATING SAWS IS PROHIBITED.
 6. CONSULT WWW.GREENSPANPROFILES.COM FOR ALLOWABLE LOADS AND SPACING OF ATTACHMENTS



CEILING SUPPORT TEE		
APPLICATION: FREEZER OR COOLER	NOTES:	
SCALE: NTS	REVISION: 2	DATE: 4-8-16
DRAWN: DG	DATE: 8-30-12	
CHECK:	DATE:	
21200 FM362, WALLER, TEXAS 77484	281-807-7400	WWW.GREENSPANPROFILES.COM