

LT-AD-001

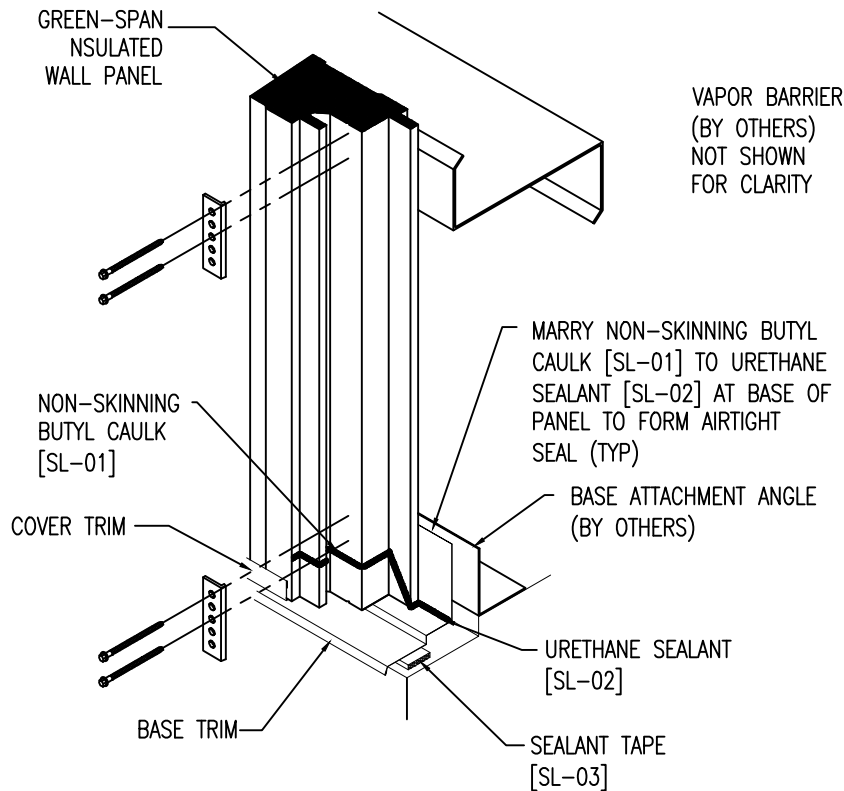

IN ADDITION TO THE PERIMETER SEALANTS APPLIED BETWEEN THE INTERIOR PANEL SURFACE AND THE STRUCTURE, NON-SKINNING BUTYL MUST BE APPLIED ALONG THE PANEL SIDE-LAP TO PROVIDE AN AIR AND WATER BARRIER. DEPENDING ON THE PROJECT REQUIREMENTS AND LOCATION, THE BUTYL MAY BE REQUIRED ALONG THE INTERIOR GROOVE, EXTERIOR GROOVE OR BOTH. PLEASE CONSULT THE CONSTRUCTION DRAWINGS AND THE MECHANICAL DESIGN PROFESSIONAL FOR PARTICULAR PLACEMENT OF SEALANTS. THE BEAD SIZE MUST BE LARGE ENOUGH (TYPICALLY 1/4" DIAMETER) TO PROVIDE FULL CONTACT BETWEEN THE TONGUE AND GROOVE OF THE PANELS. FURTHER, THE SIDE-LAP SEALANT MUST MARRY INTO THE PERIMETER SEALANT BY APPLYING SEALANT PIGTAILS THUS PROVIDING CONTINUITY OF THE SEAL-LINE.

3/8" UNIFORM BEAD OF NON-SKINNING BUTYL SEALANT MUST BE APPLIED IN EITHER OR BOTH FEMALE GROOVES DEPENDING ON VAPOR SEAL REQUIREMENTS

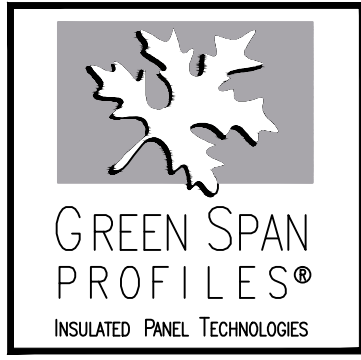
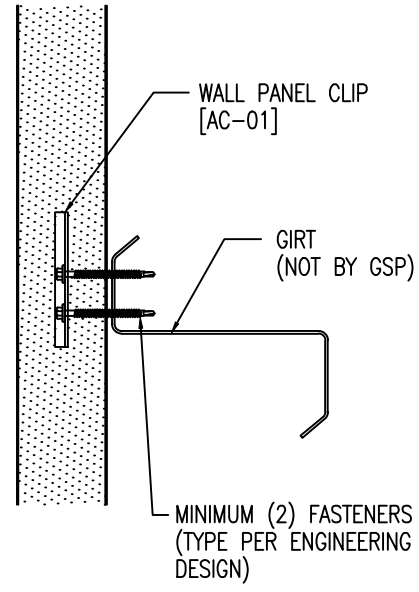
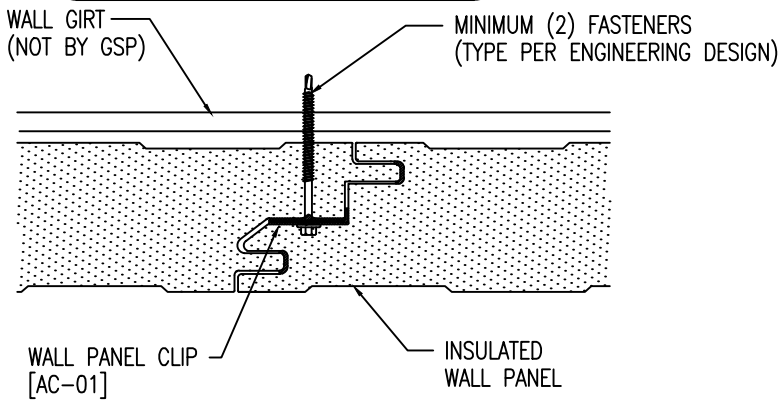

ATTACHMENT DETAIL		
APPLICATION: LOW TEMPERATURE	NOTES:	
SCALE: NTS	REVISION: 2	DATE: 4-8-16
DRAWN: DG	DATE: 8-30-12	
CHECK:	DATE:	
21200 FM362, WALLER, TEXAS 77484	281-807-7400	WWW.GREENSPANPROFILES.COM