

NOTE: FIELD REMOVE LINER AND INSULATION AT CUTBACK

RL-E-001

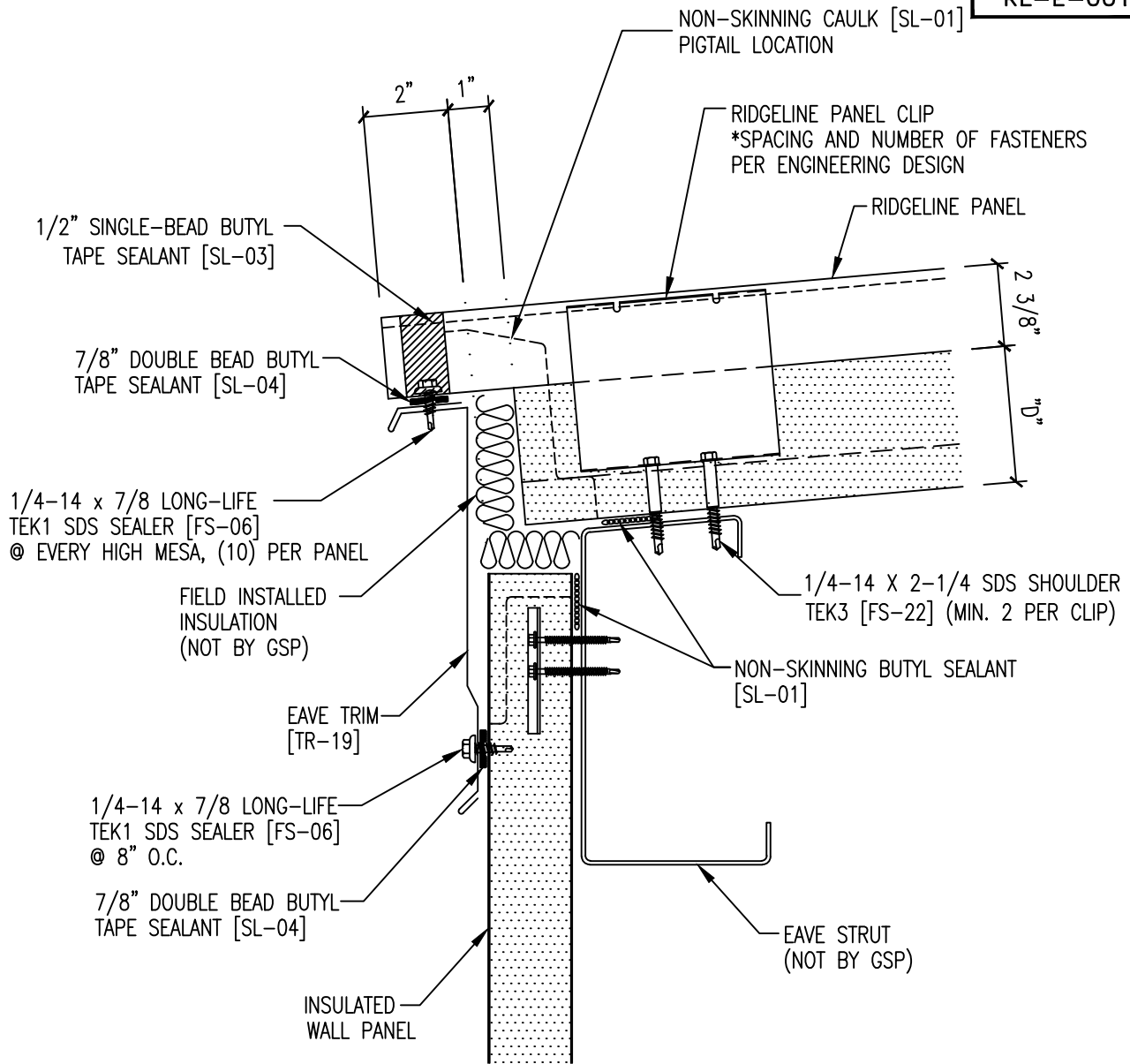

NOTE:

1. "D" = ROOF PANEL THICKNESS (AVAILABLE THICKNESS = 2.5, 3, 4, 5, OR 6)
2. FIELD REMOVE LINER AND INSULATION AT CUTBACK
3. DIMENSIONS SHOW ARE FOR 3" THICK ROOF PANEL. ADJUST DIMENSION PROPORTIONALLY FOR OTHER ROOF PANELS THICKNESS.
4. FILLER INSULATION MATERIAL AND APPLICATION IS SPECIFIED BY THE PROJECT DESIGNER.

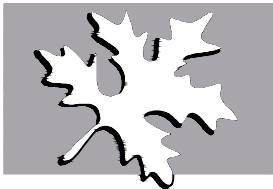

GREEN SPAN  
PROFILES®

INSULATED PANEL TECHNOLOGIES

## LOW EAVE

APPLICATION: ROOF

NOTES:

SCALE: NTS

REVISION: 3

DATE: 6-03-16

DRAWN: JC

DATE: 10-20-13

CHECK:

DATE:

21200 FM362, WALLER, TEXAS 77484

281-807-7400

WWW.GREENSPANPROFILES.COM