



DEPARTMENT OF REGULATORY AND ECONOMIC RESOURCES (RER)
BOARD AND CODE ADMINISTRATION DIVISION

MIAMI-DADE COUNTY
PRODUCT CONTROL SECTION
11805 SW 26 Street, Room 208
Miami, Florida 33175-2474
T (786) 315-2590 F (786) 315-2599

www.miamidade.gov/economy

NOTICE OF ACCEPTANCE (NOA)

Green-Span Profiles, L.P.
21200 FM 362
Waller, TX 77484

SCOPE:

This NOA is being issued under the applicable rules and regulations governing the use of construction materials. The documentation submitted has been reviewed and accepted by Miami-Dade County RER- Product Control Section to be used in Miami Dade County and other areas where allowed by the Authority Having Jurisdiction (AHJ).

This NOA shall not be valid after the expiration date stated below. The Miami-Dade County Product Control Section (In Miami Dade County) and/or the AHJ (in areas other than Miami Dade County) reserve the right to have this product or material tested for quality assurance purposes. If this product or material fails to perform in the accepted manner, the manufacturer will incur the expense of such testing and the AHJ may immediately revoke, modify, or suspend the use of such product or material within their jurisdiction. RER reserves the right to revoke this acceptance if it is determined by Miami-Dade County Product Control Section that this product or material fails to meet the requirements of the applicable building code.

This product is approved as described herein and has been designed to comply with the High Velocity Hurricane Zone of the Florida Building Code.

DESCRIPTION: "IRP Series Metal Roof Panel System"

APPROVAL DOCUMENT: Drawing No. 438-0191T-16A-C, titled "Ridgeline", sheets 1 through 3 of 3, prepared by Green Span Profiles, dated March 06, 2017, last revision #C dated March 05, 2021, signed and sealed by Brian Neal Jaks, P.E., on April 05, 2021 bearing the Miami-Dade County Product Control Renewal Stamp with the Notice of Acceptance number and the expiration date by the Miami-Dade County Product Control Section.

MISSILE IMPACT RATING: Large and Small Missile Impact Resistant

LABELING: Each panel shall bear a permanent label with the manufacturer's name or logo, city, state and the following statement: "Miami-Dade County Product Control Approved", unless otherwise noted herein.

RENEWAL of this NOA shall be considered after a renewal application has been filed and there has been no change in the applicable building code negatively affecting the performance of this product.

TERMINATION of this NOA will occur after the expiration date or if there has been a revision or change in the materials, use, and/or manufacture of the product or process. Misuse of this NOA as an endorsement of any product, for sales, advertising or any other purposes shall automatically terminate this NOA. Failure to comply with any section of this NOA shall be cause for termination and removal of NOA.

ADVERTISEMENT: The NOA number preceded by the words Miami-Dade County, Florida, and followed by the expiration date may be displayed in advertising literature. If any portion of the NOA is displayed, then it shall be done in its entirety.

INSPECTION: A copy of this entire NOA shall be provided to the user by the manufacturer or its distributors and shall be available for inspection at the job site at the request of the Building Official.

This NOA **renews NOA #21-0412.03** and consists of this page 1, evidence submitted pages E-1, E-2 and E-3 as well as approval document mentioned above.

The submitted documentation was reviewed by **Helmy A. Makar, P.E., M.S.**



Helmy A. Makar
10/20/2022

NOA No. 22-0916.07
Expiration Date: 12/07/2027
Approval Date: 10/20/2022
Page 1

Green-Span Profiles, L.P.

NOTICE OF ACCEPTANCE: EVIDENCE SUBMITTED

1. EVIDENCE SUBMITTED UNDER PREVIOUS APPROVAL # 17-0619.08

A. DRAWINGS

1. *Drawing No. 438-091T-16A-C, titled "Ridgeline", sheets 1 through 3 of 3, prepared by Green Span Profiles, dated March 06, 2017, last revision #A dated March 06, 2017, signed and sealed by Brian Neal Jaks, P.E., on Sep. 26, 2017.*

B. TESTS

1. *Test report on Large Missile Impact Test on Green Span Profiles Roof Panel, prepared by Force Engineering & Testing, Inc., Report No. 438-0191T-16D-F, dated 09/21/2016, signed and sealed by Terrence E. Wolfe, P.E.*
2. *Test report on Uniform Static Air Pressure Test in accordance with TAS 125-03 per ASTM E 1592-01/05 on Green Span Profiles Roof Panel, prepared by Force Engineering & Testing, Inc., Report No. 438-0191T-16A-C, dated 09/15/2016, signed and sealed by Terrence E. Wolfe, P.E.*
3. *Susceptibility to leakage test in accordance with FM 4471 Appendix G on Green Span Profiles Roof Panel, prepared by Force Engineering & Testing, Inc., Report No. 438-0191T-16G, dated 10/25/2016, signed and sealed by Terrence E. Wolfe, P.E.*
4. *2000 hour Salt Spray Test in accordance with ASTM B117 on Green Span Profiles Roof Panel, prepared by PRI, dated July 27, 2015, signed by L. J. Chris Friedner, Client Service Manager.*
5. *1000 hour Salt Spray Test per ASTM B117 and 2000 hour Accelerated Weathering Test in accordance with ASTM B 117 on Green Span Profiles Roof Panel, prepared by PRI, dated Feb. 22, 2013, signed & Sealed by Zachary R. Priest, P.E.*

C. CALCULATIONS

1. *Calculations titled "Green Span Profiles", dated 04/11/2017, pages 1 through 4 of 4, prepared by Brian Neal Jaks, P.E., signed and sealed by Brian Neal Jaks, P.E.*

D. QUALITY ASSURANCE

1. *By Miami-Dade County Department of Regulatory and Economic Resources (RER).*

E. MATERIAL CERTIFICATIONS

1. *Tensile Test Report No. B16090854, prepared by Element, dated 09/29/16, signed by Maurice Cochran.*

F. OTHERS

1. *Letter prepared by Green Span Profiles, dated April 11, 2017, signed and sealed by Brian N. Jaks, P.E., certifies that this roof panel is in compliance with the Florida Building Code, 2014 Edition.*

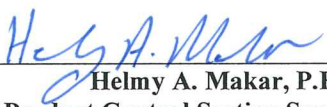

Helmy A. Makar, P.E., M.S.
Product Control Section Supervisor
NOA No. 22-0916.07
Expiration Date: 12/07/2027
Approval Date: 10/20/2022

Green-Span Profiles, L.P.

NOTICE OF ACCEPTANCE: EVIDENCE SUBMITTED

2. EVIDENCE SUBMITTED UNDER PREVIOUS APPROVAL # 19-0417.04

A. DRAWINGS

1. *Drawing No. 438-0191T-16A-C, titled "Ridgeline", sheets 1 through 3 of 3, prepared by Green Span Profiles, dated March 06, 2017, last revision #B dated April 09, 2019, signed and sealed by Brian Neal Jaks, P.E., on April 12, 2019.*

B. TESTS

1. *None.*

C. CALCULATIONS

1. *None.*

D. QUALITY ASSURANCE

1. *By Miami-Dade County Department of Regulatory and Economic Resources (RER).*

E. MATERIAL CERTIFICATIONS

1. *None.*

F. OTHERS

1. *None.*

3. EVIDENCE SUBMITTED UNDER PREVIOUS APPROVAL # 21-0412.03

A. DRAWINGS

1. *Drawing No. 438-0191T-16A-C, titled "Ridgeline", sheets 1 through 3 of 3, prepared by Green Span Profiles, dated March 06, 2017, last revision #C dated March 05, 2021, signed and sealed by Brian Neal Jaks, P.E., on April 05, 2021.*

B. TESTS

1. *None.*

C. CALCULATIONS

1. *None.*

D. QUALITY ASSURANCE

1. *By Miami-Dade County Department of Regulatory and Economic Resources (RER).*

E. MATERIAL CERTIFICATIONS

1. *None.*

F. OTHERS

1. *FBC, 2020 Edition Compliance letter, prepared by Green Span Profiles, dated 03/08/2021, signed and sealed by Brian Neal Jaks, P.E., on 04/05/2021.*

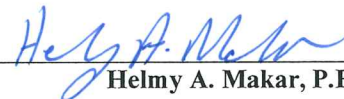

Helmy A. Makar, P.E., M.S.
Product Control Section Supervisor
NOA No. 22-0916.07
Expiration Date: 12/07/2027
Approval Date: 10/20/2022

Green-Span Profiles, L.P.

NOTICE OF ACCEPTANCE: EVIDENCE SUBMITTED

4. NEW EVIDENCE SUBMITTED

A. DRAWINGS

1. *Drawing No. 438-0191T-16A-C, titled "Ridgeline", sheets 1 through 3 of 3, prepared by Green Span Profiles, dated March 06, 2017, last revision #C dated March 05, 2021, signed and sealed by Brian Neal Jaks, P.E., on April 05, 2021.*

B. TESTS

1. *None.*

C. CALCULATIONS

1. *None.*

D. QUALITY ASSURANCE

1. *By Miami-Dade County Department of Regulatory and Economic Resources (RER).*

E. MATERIAL CERTIFICATIONS

1. *None.*

F. OTHERS

1. *FBC, 2020 Edition Compliance letter, prepared by Green Span Profiles, dated 09/07/2022, signed and sealed by Brian Neal Jaks, P.E., on 09/07/2022.*



**Helmy A. Makar, P.E., M.S.
Product Control Section Supervisor**

NOA No. 22-0916.07

Expiration Date: 12/07/2027

Approval Date: 10/20/2022

- THE INSULATED METAL ROOF PANEL SYSTEM HAS BEEN DESIGNED IN ACCORDANCE WITH THE FLORIDA BUILDING CODE 2020, HVHZ.
- ALL INSULATED METAL ROOF PANELS COME IN A MAX. WIDTH OF 42" AND A LINER OF 26GA (0.019") MIN. AND A FACER OF 26GA (0.019") MIN. WITH A POLYISOCYANURATE FOAM CORE.
- THE SUPPORTING STRUCTURE TO WHICH THE ROOF SYSTEM WILL BE ATTACHED SHALL BE A MIN. OF 14GA (0.075") STEEL WITH A Fy OF 50KSI.
- THIS INSULATED PANEL ROOF SYSTEM HAS BEEN TESTED IN ACCORDANCE WITH THE FLORIDA BUILDING CODE.
 - ACCELERATED WEATHERING TESTING OF COATING PER ASTM G26
 - SALT SPRAY TESTING PER ASTM B117
 - UPLIFT RESISTANCE TEST PER TAS-125
 - LARGE MISSILE IMPACT TEST PER TAS-201
 - STANDING WATER TEST PER TAS 114 APP G
- MINIMUM ALLOWABLE ROOF SLOPE SHALL BE 1/2" PER 12"
- MAXIMUM ALLOWABLE ROOF SLOPE SHALL BE LESS THAN 2" PER 12".
- THE MAXIMUM UPLIFT PRESSURE SHALL BE CALCULATED USING THE FOLLOWING ALLOWABLES.
 - MAXIMUM BENDING MOMENT OF THE PANEL AT SUPPORTS: 123.8 LBS.
 - MAXIMUM BENDING MOMENT OF THE PANEL BETWEEN SUPPORTS: 99.0 LBS.
 - MAXIMUM PANEL INTERIOR SUPPORT REACTION: 272.3 LBS.
 - MAXIMUM PANEL EXTERIOR SUPPORT REACTION: 99.0 LBS.
 - EI VALUE OF RIDGELINE PANEL: 3,006,308 LB-IN²
 - MAXIMUM DEFLECTION OF RIDGELINE ROOF PANEL: L/240
- MAXIMUM ALLOWABLE PANEL SPAN: 5'-0"
- MAXIMUM ALLOWABLE SPANS AND UPLIFT PRESSURES.

SPAN	UPLIFT PRESSURE
5'-0"	-49.5 PSF
4'-6"	-55.2 PSF
4'-0"	-60.9 PSF
3'-6"	-66.7 PSF
3'-0"	-72.4 PSF
2'-6"	-78.1 PSF
- ALL SCREWS SHALL BE CORROSION RESISTANT SELF DRILLING SCREWS.
- THE INSULATED METAL ROOF PANEL SHALL NOT BE DESIGNED TO ACT AS A DIAPHRAM.

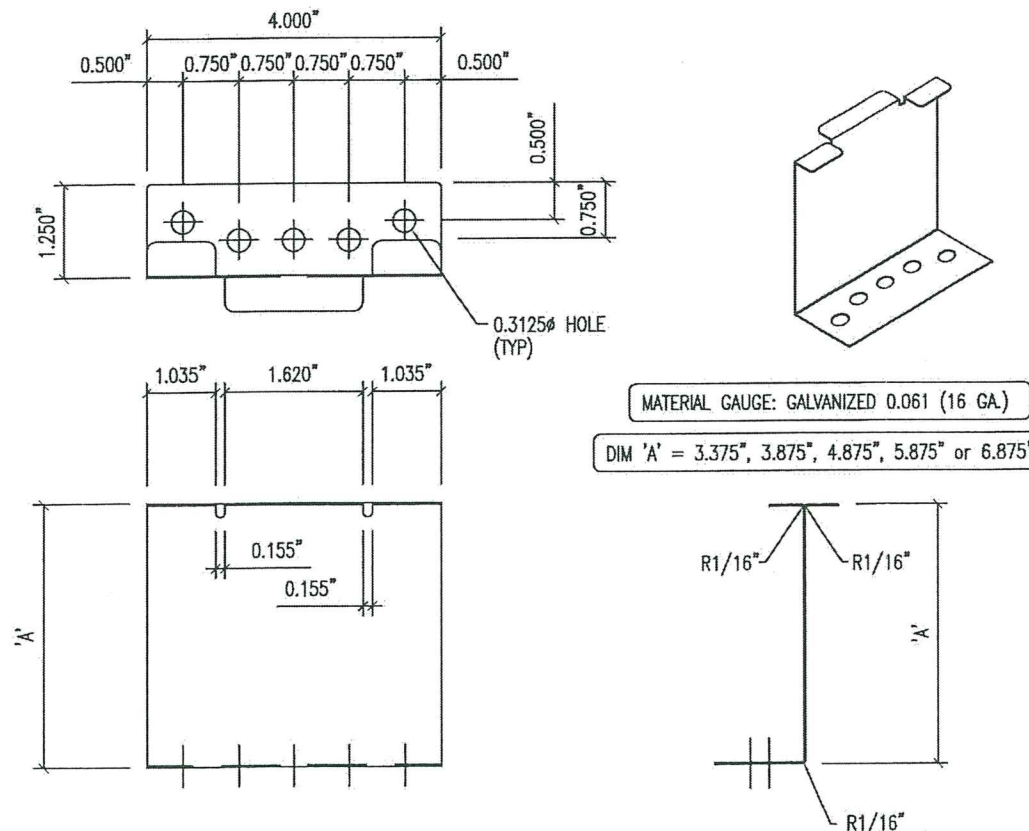

PRODUCT RENEWED
as complying with the Florida
Building Code
Acceptance No. 22-0916.07
Expiration Date 12/07/2027
By *Helga A. Miller*
Miami Date Product Control

NON-SKINNING BUTYL
SEALANT [SL-01]

PRODUCT REVISED
as complying with the Florida
Building Code
Acceptance No. 21-0412.03
Expiration Date 12/07/2022
By *Helga A. Miller*
Miami Date Product Control

1/4-14 x 7/8 LONG-LIFE
TEK1 SDS SEALER [FS-06]

1/4-14 x 2-1/4 SDS
SHOULDER TEK3

1/4-14 x _ DP3 CONCEALOR
[FS-05-]

7/8" x 3/16" DOUBLE BEAD
BUTYL TAPE SEALANT [SL-04]

2-1/2" x _ TRIPLE-BEAD BUTYL
TAPE SEALANT [SL-05]

1/2" SINGLE-BEAD BUTYL
TAPE SEALANT [SL-03]

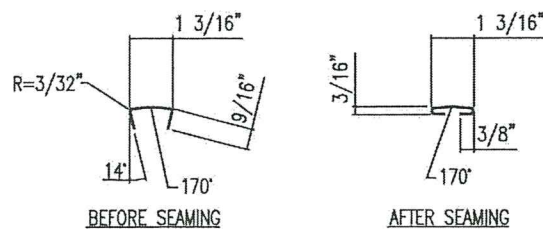
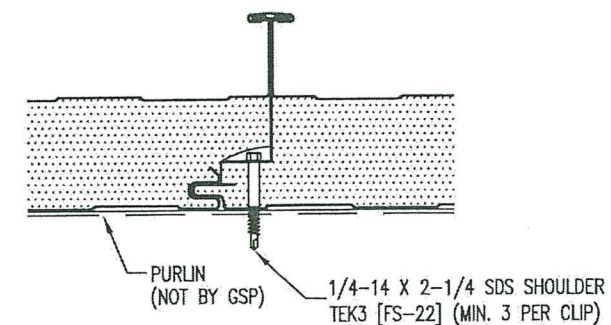

SEAM CAP

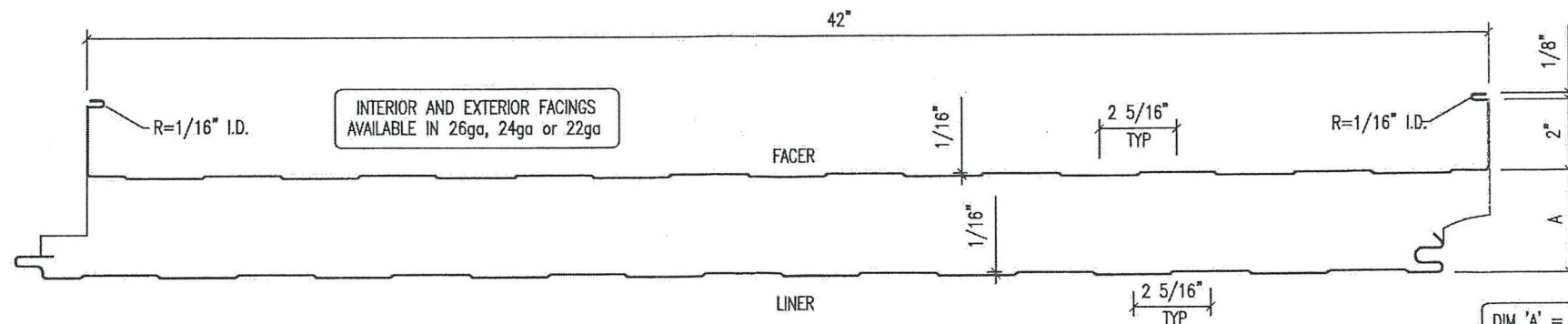

DIM 'A' = 2.5", 3", 4", 5", or 6"

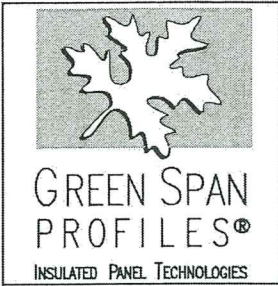

BUILDING CODE UPDATE	3/5/21
BUILDING CODE UPDATE	4/9/19
APPROVAL	3/6/17
DATE:	DATE:
REL BY:	DESCRIPTION:
DATE:	SCALE:
3/6/17	N.T.S.
DRAWN:	CHECK:
J.C.	C.T.

PRODUCT NAME:	RIDGELINE
MANUFACTURER:	GREEN SPAN PROFILES
DOCUMENT NUMBER:	438-0191T-16A-C
PREPARED BY:	BRIAN N. JAKS, FLPE #70159

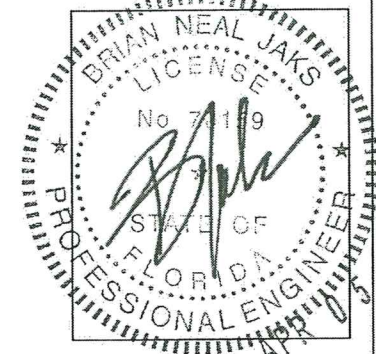

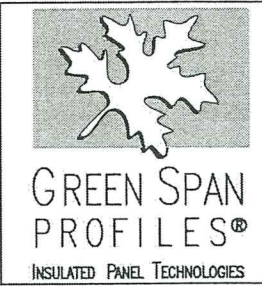

			3/6/17		
		A	JC	APPROVAL	DATE: 3/6/17
				REL BY:	DESCRIPTION: N.T.S.
				DATE:	SCALE: N.T.S.
				DRAWN:	CHECK: J.C.
					C.T.

PRODUCT NAME:	RIDGELINE
MANUFACTURER:	GREEN SPAN PROFILES
DOCUMENT NUMBER:	438-0191T-16A-C
PREPARED BY:	BRIAN N. JAKS, FLPE #70159

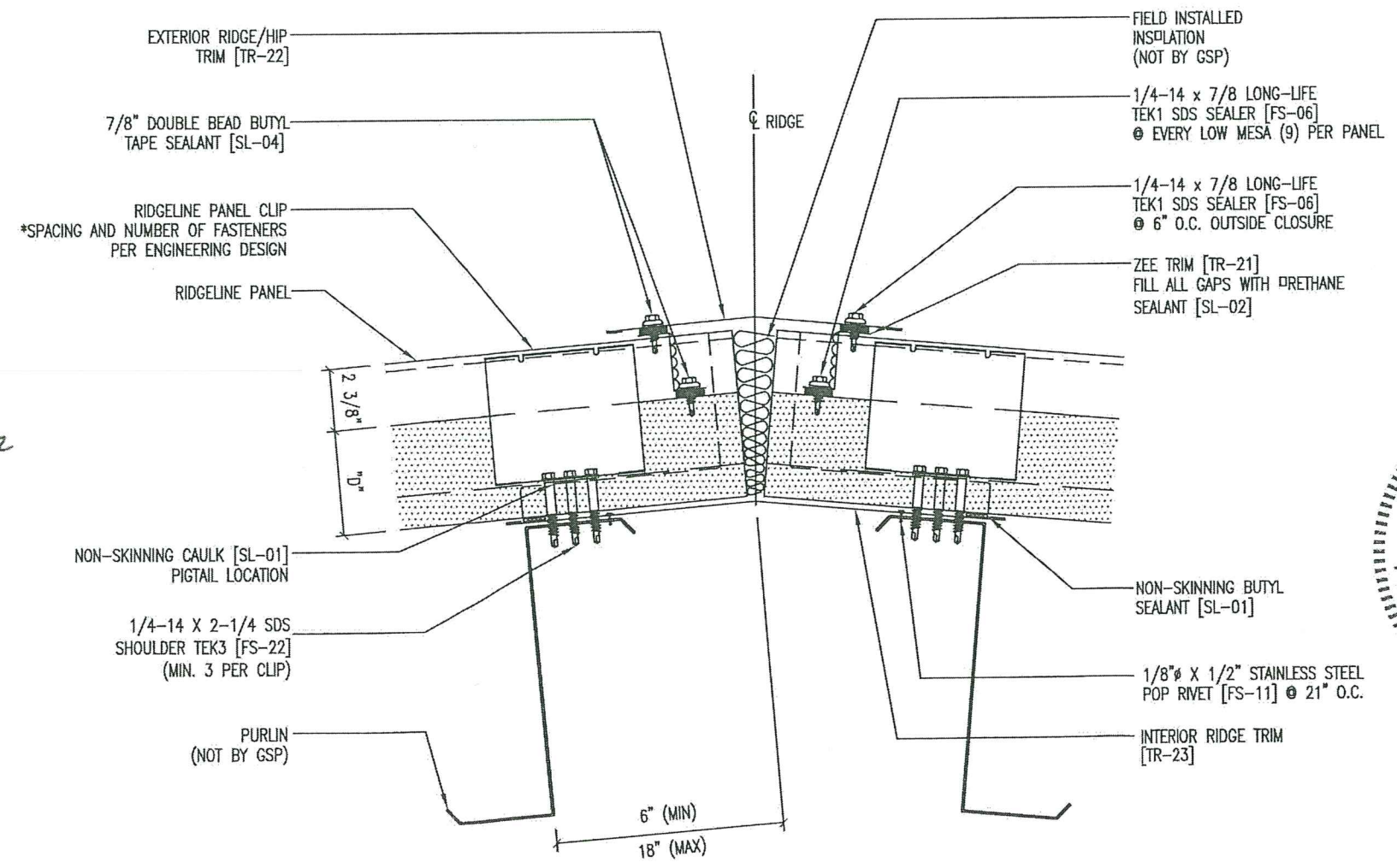
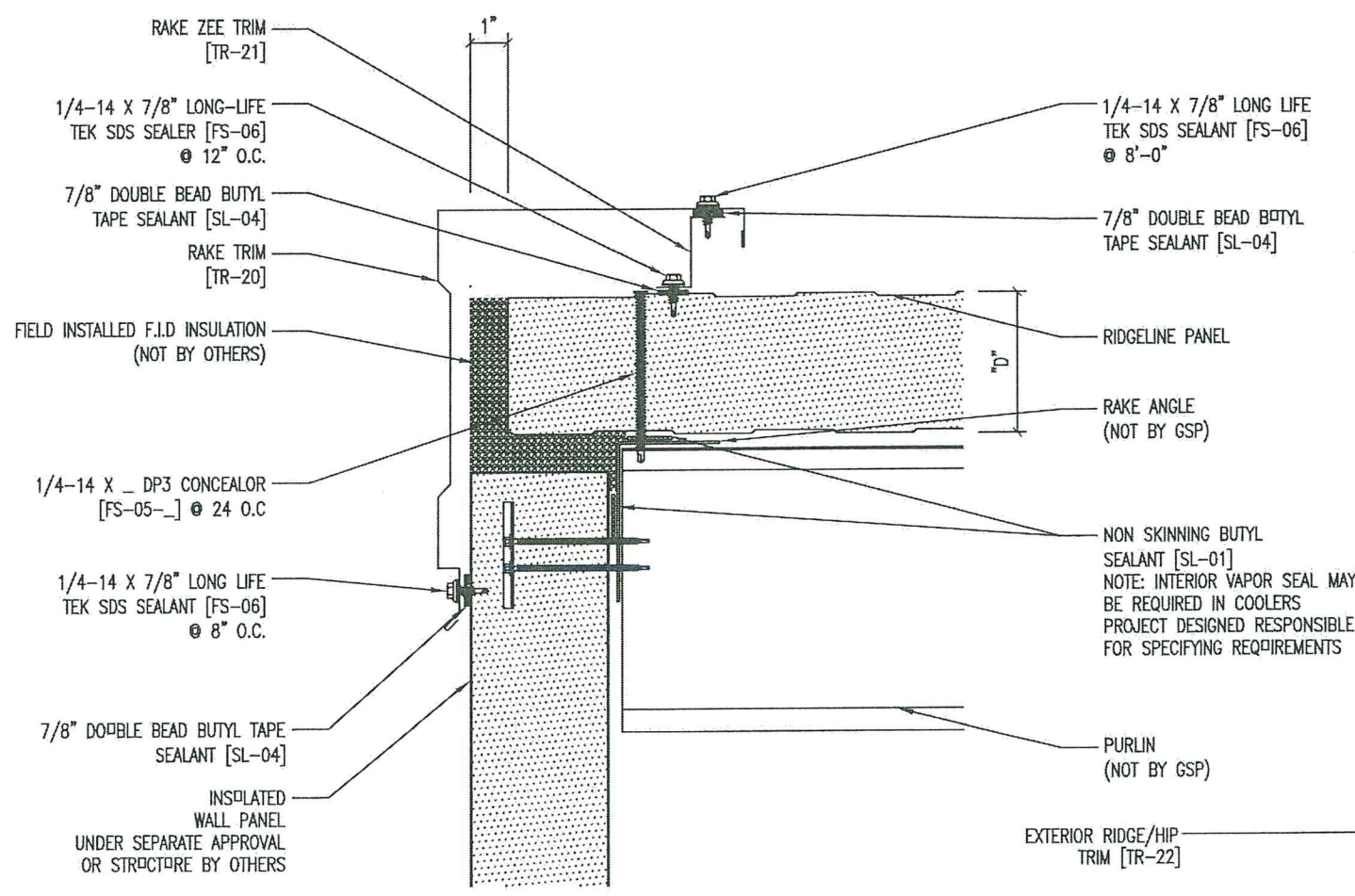
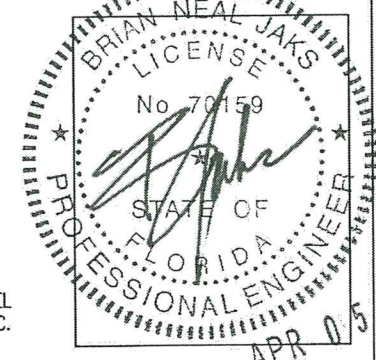

PRODUCT REVISED
as complying with the Florida
Building Code
Acceptance No. 21-0412.03
Expiration Date 12/07/2022
By *Helga A. Mohr*
Miami Design Product Control

PRODUCT RENEWED
as complying with the Florida
Building Code
Acceptance No. 22-0916.07
Expiration Date 12/07/2027
By *Helga A. Mohr*
Miami Design Product Control

NOTE: FIELD REMOVE LINER AND INSULATION AT CUTBACK

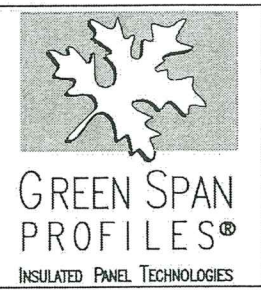
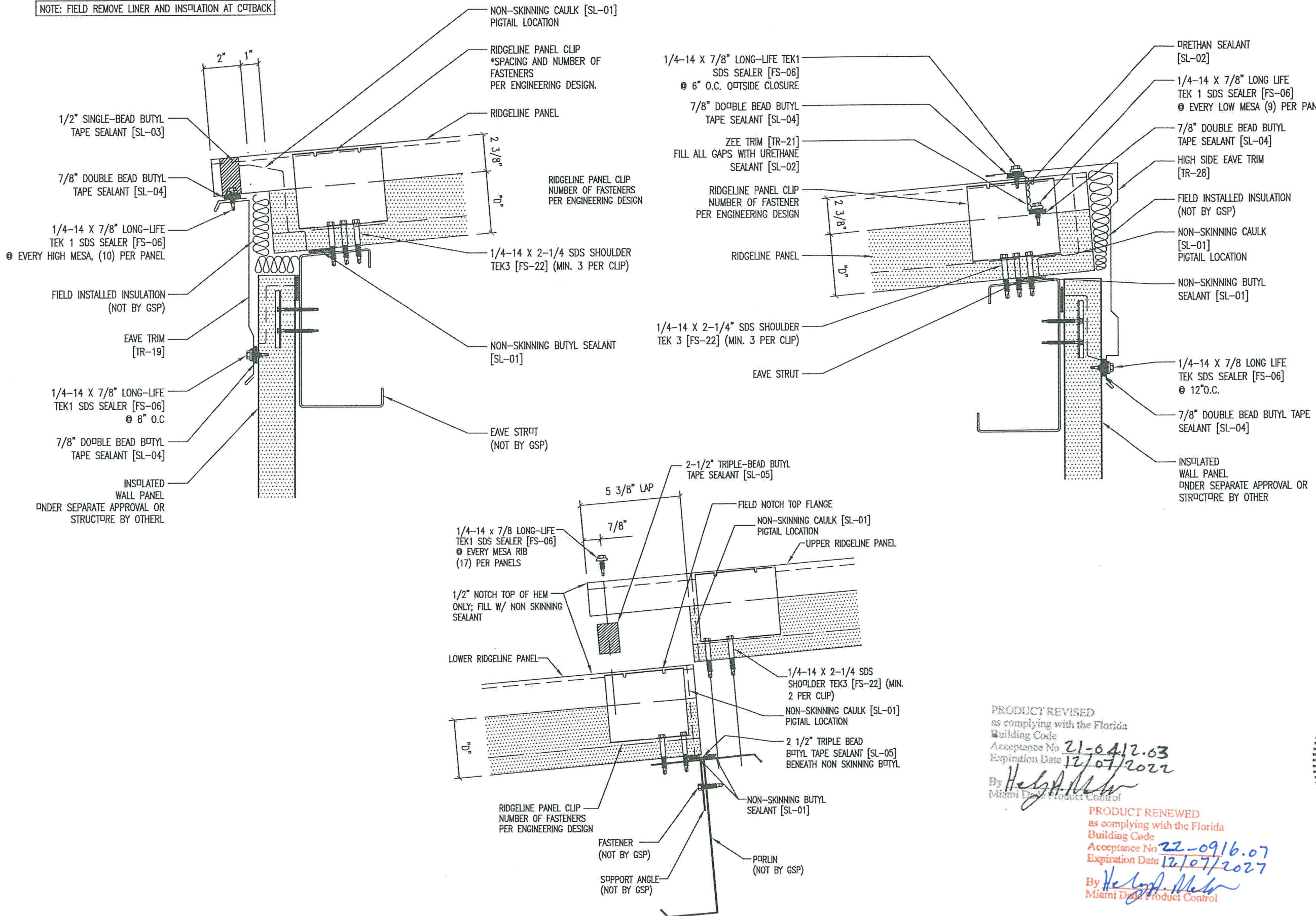

APPROVAL	3/6/17	DATE:	
REL BY:	J.C.	DESCRIPTION:	N.T.S.
DATE:	3/6/17	SCALE:	N.T.S.
DRAWN:	J.C.	CHECK:	C.T.

PRODUCT NAME:	RIDGELINE
MANUFACTURER:	GREEN SPAN PROFILES
DOCUMENT NUMBER:	438-0191T-16A-C
PREPARED BY:	BRIAN N. JAKS, FLPE #70159

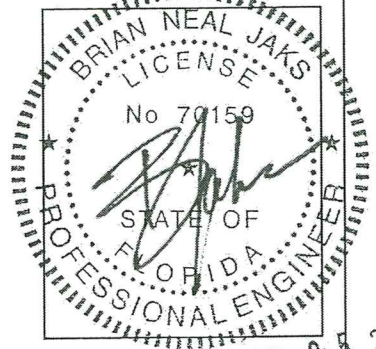

PRODUCT REVISED
 as complying with the Florida
 Building Code
 Acceptance No. 21-0412.03
 Expiration Date 12/07/2022
 By *Helga Albrecht*
 Miami Data Product Control

PRODUCT RENEWED
 as complying with the Florida
 Building Code
 Acceptance No. 22-0916.07
 Expiration Date 12/07/2027
 By *Helga Albrecht*
 Miami Data Product Control